

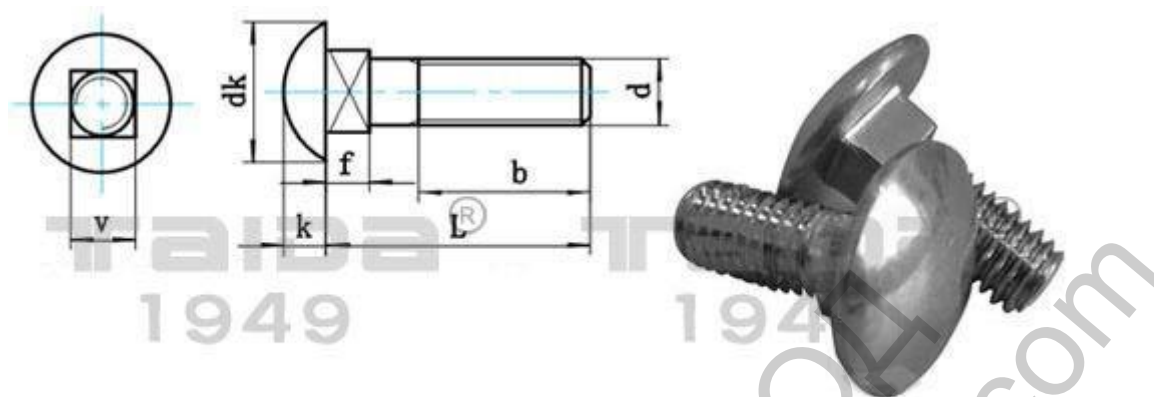

# Болт коларски



d	M5	M6	M8	M10	M12	M16	M20	
P	0.8	1	1.25	1.5	1.75	2	2.5	
dk	max	13.55	16.55	20.65	24.65	30.65	38.8	46.8
	min	12.45	15.45	19.35	23.35	29.35	37.2	45.2
v	max	5.48	6.48	8.58	10.58	12.7	16.7	20.84
	min	4.52	5.52	7.42	9.42	11.3	15.3	19.16
f	max	4.1	4.6	5.6	6.6	8.75	12.9	15.9
	min	2.9	3.4	4.4	5.4	7.25	11.1	14.1
k	max	3.3	3.88	4.88	5.38	6.95	8.95	11.05
	min	2.7	3.12	4.12	4.62	6.05	8.05	9.95
L	16 - 200							

Ташев-Галвинг ООД  
www.tashev-galving.com